

INSTALLATION AND OPERATING INSTRUCTIONS

Steam distribution system
OptiSorp

Thank you for choosing Condair

Installation date (MM/DD/YYYY):

Commissioning date (MM/DD/YYYY):

Site:

Model:

Serial number:

Proprietary Notice

This document and the information disclosed herein are proprietary data of Condair Group AG. Neither this document, nor the information contained herein shall be reproduced, used, or disclosed to others without the written authorisation of Condair Group AG, except to the extent required for installation or maintenance of recipient's equipment.

Liability Notice

Condair Group AG does not accept any liability due to incorrect installation or operation of the equipment or due to the use of parts/components/equipment that are not authorised by Condair Group AG.

Copyright Notice

© Condair Group AG, All rights reserved.

Technical modifications reserved

Contents

1	Notes on steam distribution system OptiSorp	4
1.1	OptiSorp – Steam distribution system for very short humidification distance	4
1.2	Positioning of the steam distribution system	4
1.3	Determination of steam absorption distance	5
1.4	Notes on installation	5
2	Notes for the planning engineer	6
2.1	Layout	6
2.2	Overview OptiSorp systems	6
2.3	Dimension diagrams	7
2.4	Power selection diagram OptiSorp Systems 1...4	8
2.5	Type key	9
2.6	Determination of the humidification distance “B _N ”	9
2.7	Planning data OptiSorp steam distribution system (for faxing!)	10
2.8	Determination of the OptiSorp Systems	11
3	Mounting	13
3.1	Safety	13
3.2	Delivery	13
3.3	Mounting positions	13
3.4	Mounting overview OptiSorp systems	14
3.5	Mounting the premounted OptiSorp system	15
3.6	Mounting the different parts of the OptiSorp system	16
3.7	OptiSorp Support (accessory)	17
4	Putting into operation and operation	18
4.1	Putting into operation	18
4.2	Operation	18
5	Spare parts list	19
6	Appendix	20
6.1	Drilling template	20

1 Notes on steam distribution system OptiSorp

1.1 OptiSorp – Steam distribution system for very short humidification distance

The OptiSorp is made from stainless steel and high-grade plastic components. It is designed for connection to the Condair steam humidifiers. The OptiSorp steam distribution system is installed directly in the air duct or in an air-handling unit. It comprises horizontal collector pipes and several vertical pipes provided with steam nozzles. The OptiSorp separates the condensate from the inlet steam and feeds this uniformly and drip-free to the air flow. In particular the steam absorption distance is considerably less compared with conventional steam distribution pipes.

Note: To ensure a safe support of the collector pipes we recommend the use of the specially designed support for the steam distribution system OptiSorp. The entire support is made from stainless steel and available in four different mounting sets for duct heights ranging from 450 to 3200 mm (see table in [chapter 3.7](#)). The mounting sets comprise all necessary parts for the correct support of a OptiSorp system.

1.2 Positioning of the steam distribution system

The positioning of the steam distribution system should be determined when laying out the air-conditioning system. The following points should be observed to ensure correct humidification of the air. The conditions must be maintained exactly to ensure that the OptiSorp system satisfies the high demands made of it. A layout based on incorrect data, an unfavorable installation position or wrong installation can result in excessive humidity with separation of condensate and therefore to damage from water. The air duct must therefore be sealed in the area of the absorption distance and provided with a water drainage tray with outlet. The system is preferably fitted immediately following the air heater (and before the cooling coils). Other installation situations require additional care. A viewing port immediately following the system is highly recommended for installation and inspection of operation of the installation. Installation of the system is always made laterally to the air flow. With vertical air flow the nozzle tubes are fitted at an angle of 20° to 30° to enable the condensate to flow away easily.

With exception of determination of the steam absorption distance, the same basic rules apply to the OptiSorp steam distribution system as to the standard steam distributor pipes (see installation and operating instructions of the humidifier).

1.3 Determination of steam absorption distance

Determination of the absorption distance " B_N " depends on various factors. For simple determination of the absorption distance " B_N " the table can be used. The nominal values obtained from the table refer to an air inlet temperature of 10 °C to 30 °C. The length of the steam absorption distance can be calculated more accurately with the Condair software program. The result must be compared with the actual steam absorption distance or with the minimum spacings to be observed.

1.4 Notes on installation

Before installation check that the correct OptiSorp system is used and that the system is in accordance with the type and steam output on the specification label.

The OptiSorp is suitable for installation in air ducts or air-conditioning units. For this purpose the templates supplied are attached to the ventilation duct spaced according to the collectors. The duct plate is cut out round. The connection side of the pre-fitted system is inserted from inside through these holes. The connector pieces are then fitted on the pipes from outside and screwed to the duct wall. The collector pipes should be aligned horizontally and secured at the end on the duct wall.

For large systems or in special cases, where this type of installation is not possible, the collector pipes can be fitted individually from outside. The nozzle tubes are then inserted in the collectors in the air duct and secured with the hose clamps and O-rings. Suitable pliers are required for the installation. All parts are supplied loose for this case if required.

Then install the steam and condensate hoses according to the instructions in the installation and operating instructions of the humidifier. It is advisable to drain the condensate separately and not return it to the humidifier owing to the increased volume.

2 Notes for the planning engineer

2.1 Layout

The choice of the OptiSorp steam distribution system can be made with the Condair software programme or from the layout tables. The system is determined by the number of steam connections of the steam humidifier. This also determines the maximum steam output. The maximum possible collector lengths and collector spacing is selected depending on the duct width and height.

2.2 Overview OptiSorp systems

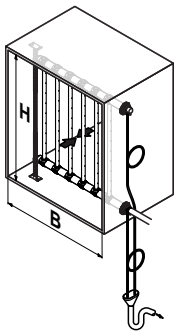
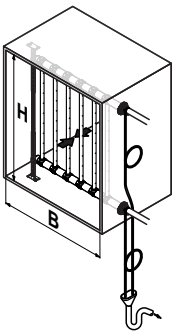
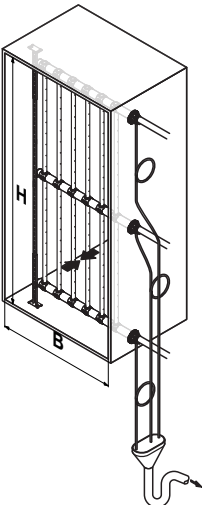
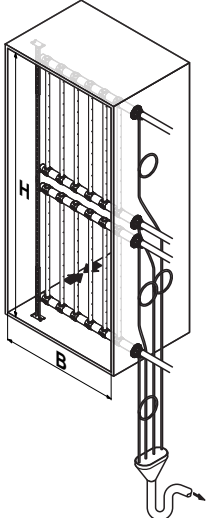
	System 1	System 2	System 3	System 4
				
Number of steam connectors	1	2	3	4
Max. steam capacity	45 (30) kg/h	90 (60) kg/h	135 (90) kg/h	180 (120) kg/h
Duct width (B)	450...2700 mm			
Duct height (H)	450...1650 mm	450...2200 mm	800...3200 mm	800...3200 mm

¹⁾ For duct width <600 mm the values in brackets apply.

2.3 Dimension diagrams

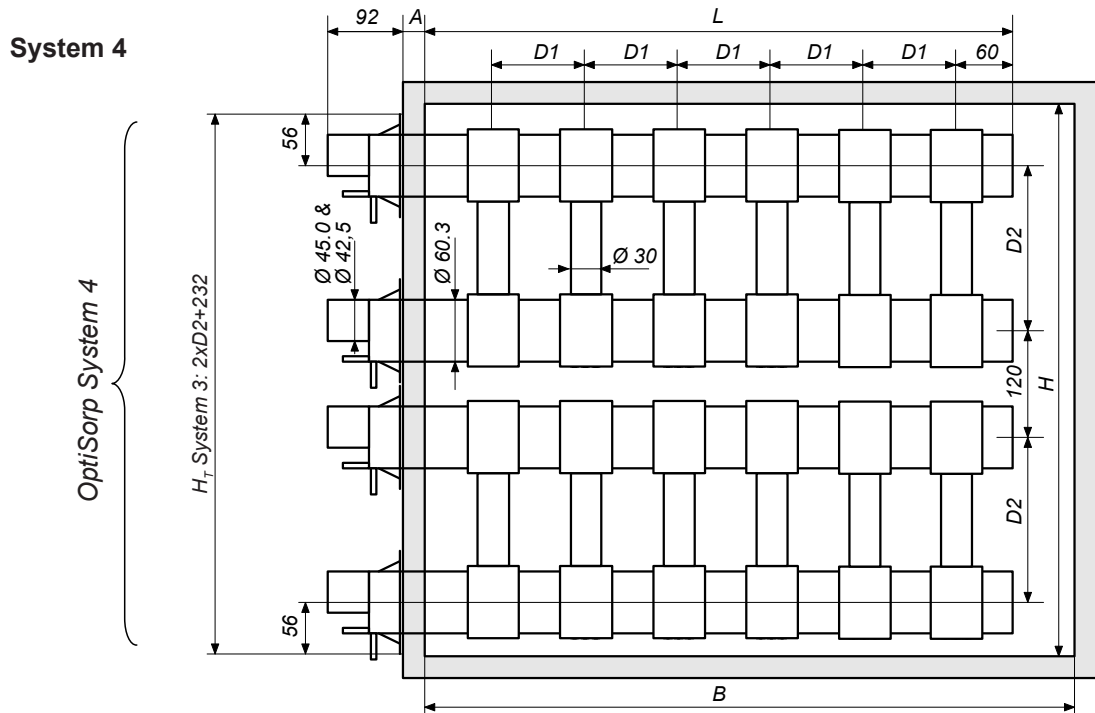
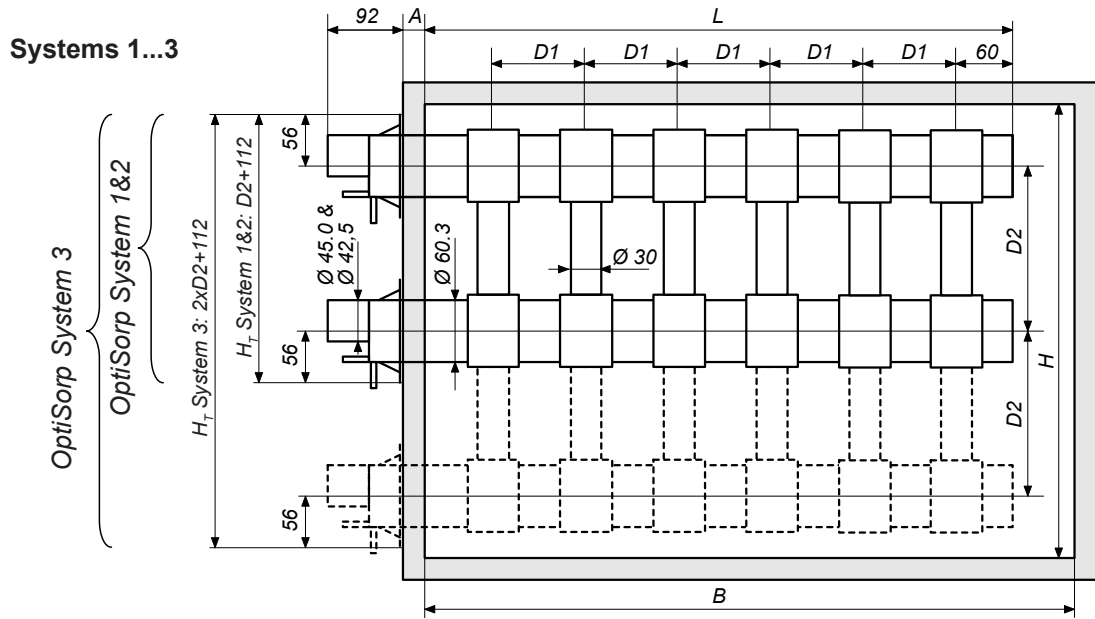

2.4 Power selection diagram OptiSorp Systems 1...4

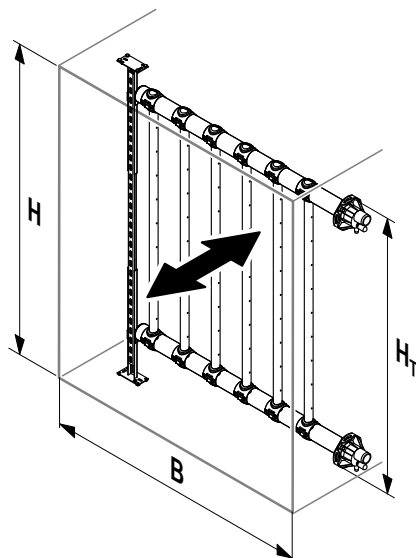

Collector length L	mm	350	500	650	800	1000	1200	1500	1800	2000	2300	2500
B min.	mm	450 ¹⁾	600	750	900	1100	1300	1600	1900	2200	2500	2700

System 1	m_D max.	kg/h	30 ¹⁾		45							
	D2	mm	350	500	650	800	1000	1200	1500			
	H min.	mm	450 ²⁾	600 ²⁾	800	950	1150	1350	1650			
	Total height H _T OptiSorp System	mm	462	612	762	912	1112	1312	1612			

System 2	m_D max.	kg/h	60 ¹⁾		90						
	D2	mm	350	500	650	800	1000	1200	1500	1800	2000
	H min.	mm	450 ²⁾	600 ²⁾	800	950	1150	1350	1650	1950	2200
	Total height H _T OptiSorp System	mm	462	612	762	912	1112	1312	1612	1912	2112

System 3	m_D max.	kg/h	90 ¹⁾		135							
	D2	mm	325	400	500	600	750	900	1050	1200	1350	1500
	H min.	mm	800	950	1150	1350	1650	1950	2300	2600	2900	3200
	Total height H _T OptiSorp System	mm	762	912	1112	1312	1612	1912	2212	2512	2812	3112

System 4	m_D max.	kg/h	120 ¹⁾		180							
	D2	mm	300	375	475	575	725	875	1050	1200	1350	1500
	H min.	mm	800 ²⁾	950 ²⁾	1150 ²⁾	1350 ²⁾	1650 ²⁾	1950 ²⁾	2300 ²⁾	2600 ²⁾	2900 ²⁾	3200 ²⁾
	Total height H _T OptiSorp System	mm	832	982	1182	1382	1682	1982	2332	2632	2932	3232

¹⁾ For "B min." <600 mm, the steam capacity of the corresponding system is limited to these values!

²⁾ If the air ducts of these systems are designed with "H min.", the mounting plates of the steam inlet will protrude on the bottom and on the top in thin-walled air ducts. If this is not desired we recommend to design the air ducts in the total height of the OptiSorp system.

2.5 Type key

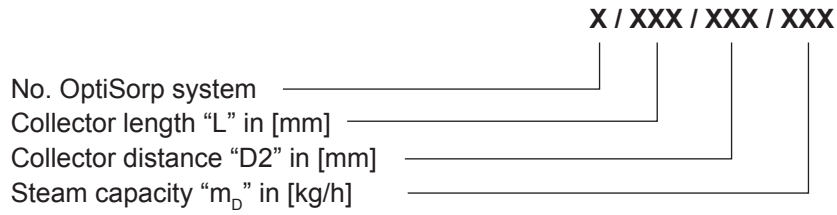

2.6 Determination of the humidification distance "B_N"

Entering humidity φ 1 in % r.H.	Leaving humidity φ 2 in % r.H.					
	40	50	60	70	80	90
5	0.22 m	0.28 m	0.36 m	0.48 m	0.66 m	1.08 m
10	0.20 m	0.26 m	0.34 m	0.45 m	0.64 m	1.04 m
20	0.16 m	0.22 m	0.30 m	0.41 m	0.58 m	0.96 m
30	0.10 m	0.17 m	0.25 m	0.36 m	0.52 m	0.88 m
40		0.11 m	0.20 m	0.30 m	0.45 m	0.79 m
50			0.13 m	0.24 m	0.38 m	0.69 m
60				0.16 m	0.30 m	0.58 m
70					0.20 m	0.45 m

The length of the absorption distance B_N in m
 is for ducts with <600 mm about 50% longer

2.7 Planning data OptiSorp steam distribution system (for faxing!)

Layout data required		Installation 1	Installation 2	Installation 3	Installation 4
1.	Clear height of air duct "B" (without insulation)	mm			
2.	Clear width of air duct "H" (without insulation)	mm			
3.	Wall thickness of air duct "A" (without insulation)	mm			
4.	Air volume per hour or	m ³ /h			
5.	Air speed	m/s			
6.	Air duct static pressure	Pa			
7.	Temperature after humidification	°C			
8.	Abs. humidity before humidification	g/kg			
9.	Humidity increase (Δx) or	g/kg			
10.	Rel. humidity after humidification	%			
11.	Humidifier capacity	kg/h			
12.	Steam humidifier selected	type			
13.	Number of steam connections	pcs.			
14.	Following air-cond. components	type			
15.	Existing humidification distance	m			
OptiSorp System selected		type			
-	Collector length (L)	mm			
-	Collector spacing (D2)	mm			
-	Steam output at 500 Pa (m_D)	kg/h			
Order		No.			

2.8 Determination of the OptiSorp Systems

Example:

Unit: Condair RS 40 400V 3~, with one steam connector

Duct width B = 1410 mm

Duct height H = 1210 mm

Max. steam capacity = 35 kg/h

1. Determination of the system

The system to be used is determined by the corresponding table of the respective device:

– Condair RS

Voltage	Condair RS					
230V/1~	5...10	—	—	—	—	—
200V/3~	—	16...30	40...60	—	—	—
230V/3~	5...10	16...30	40...60	—	—	—
380V/3~	5...10	16...40	50...80	—	—	—
① 400...415V/3~	5...10	16...40	50...80	100...120	140...160	—
440...600V/3~	10	16/20/30/40	50...80	—	—	—
Steam distribution system OptiSorp	1x System 1 ←		1x System 2	1x System 3	1x System 4	

– Condair EL

Voltage	Condair EL					
200...240V/1~	5...10	---	---	---	---	---
200V/3~	5...8	10...15	20...30	35...60	---	---
230V/3~	5...8	10...15	20...30	35...60	70...90	105...120
400...415V/3~	5...8	10...15	20...30	50...90	105...135	152...180
440...600V/3~	5...8	10...15	20...45	50...90	---	---
Steam distribution system OptiSorp	1x System 1			1x System 2	1x System 3	1x System 4

– Condair GS

Model Condair GS	23 ...	45 ...	65 ...	90 ...	130 ...	195 ...	260 ...
Steam distribution system OptiSorp	1x System 1		1x System 2		1x System 2	1x System 2 and 1x System 3	2x System 3

2. Determination of the collector length "L":

Go in the table with the collector length to the right until value "B min." is greater than the width "B" of your duct. The collector length to be selected is the value in the field to the left.

3. Determination of the maximum steam capacity of the selected system:

The determination of the required maximum steam output " m_D max." for the selected system is based on the steam output of the humidifier. In our example (Condair RS 40 with 40 kg/h steam capacity) the required steam capacity is >30 kg/h but <45 kg/h.

4. Determination of the collector distance "D2":

Go in the table of the corresponding system (selected system in the example: System 1) to the right until the value "H min." is greater than the height of your duct. The collector distance "D2" to be selected is the value in the field to the left.

Collector length L	mm	350	500	650	800	1000	1200	1500	1800	2000	2300	2500
B min.	mm	450 ¹⁾	600	750	900	1100	1350	1600	1900	2200	2500	2700



System 1	m_D max.	kg/h	30 ¹⁾	45								
	D2	mm	350	500	650	800	1000	1200	1500			
	H min.	mm	450 ²⁾	600 ²⁾	800	950	1150	1350	1650			
	Total height H_T	mm	462	612	762	912	1112	1312	1612			
OptiSorp System												

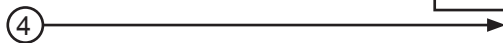

System 2	m_D max.	kg/h	60 ¹⁾	90								
	D2	mm	350	500	650	800	1000	1200	1500	1800	2000	
	H min.	mm	450 ²⁾	600 ²⁾	800	950	1150	1350	1650	1950	2200	
	Total height H_T	mm	462	612	762	912	1112	1312	1612	1912	2112	
OptiSorp System												

System 3	m_D max.	kg/h	90 ¹⁾	135								
	D2	mm	325	400	500	600	750	900	1050	1200	1350	1500
	H min.	mm	800	950	1150	1350	1650	1950	2300	2600	2900	3200
	Total height H_T	mm	762	912	1112	1312	1612	1912	2212	2512	2812	3112
OptiSorp System												

System 4	m_D max.	kg/h	120 ¹⁾	180								
	D2	mm	300	375	475	575	725	875	1050	1200	1350	1500
	H min.	mm	800 ²⁾	950 ²⁾	1150 ²⁾	1350 ²⁾	1650 ²⁾	1950 ²⁾	2300 ²⁾	2600 ²⁾	2900 ²⁾	3200 ²⁾
	Total height H_T	mm	832	982	1182	1382	1682	1982	2332	2632	2932	3232
OptiSorp System												

¹⁾ and ²⁾ see table in [chapter 2.4](#).

The following results in our example: System 1 with a collector distance "D2" of 1000 mm and a collector length "L" of 1200 mm.

3 Mounting

3.1 Safety

The OptiSorp steam distribution system must only be installed by **adequately qualified personnel**. **Observe and comply with all safety instructions in the installation and operating instructions of the steam humidifier.**

3.2 Delivery

The OptiSorp steam distribution system will be delivered either premounted or as single components. Observe the corresponding mounting instructions.

3.3 Mounting positions

The OptiSorp steam distribution system can be installed in **horizontal** or **vertical ducts**. When mounting in a vertical duct the nozzle pipes must have a minimum declination of 20° and the end pieces of the collector pipes must be turned, so that the vertical condensate connection directs straight downwards (see figure below).

Note: Before mounting the OptiSorp system check the type designation and steam capacity on the data plate to ensure that the correct OptiSorp system is installed in the right place.

In addition to this installation and operating instructions please observe and comply with the instructions regarding the steam installation (positioning, max. length of steam pipe, etc.) in the installation and operating instructions of the steam humidifier.

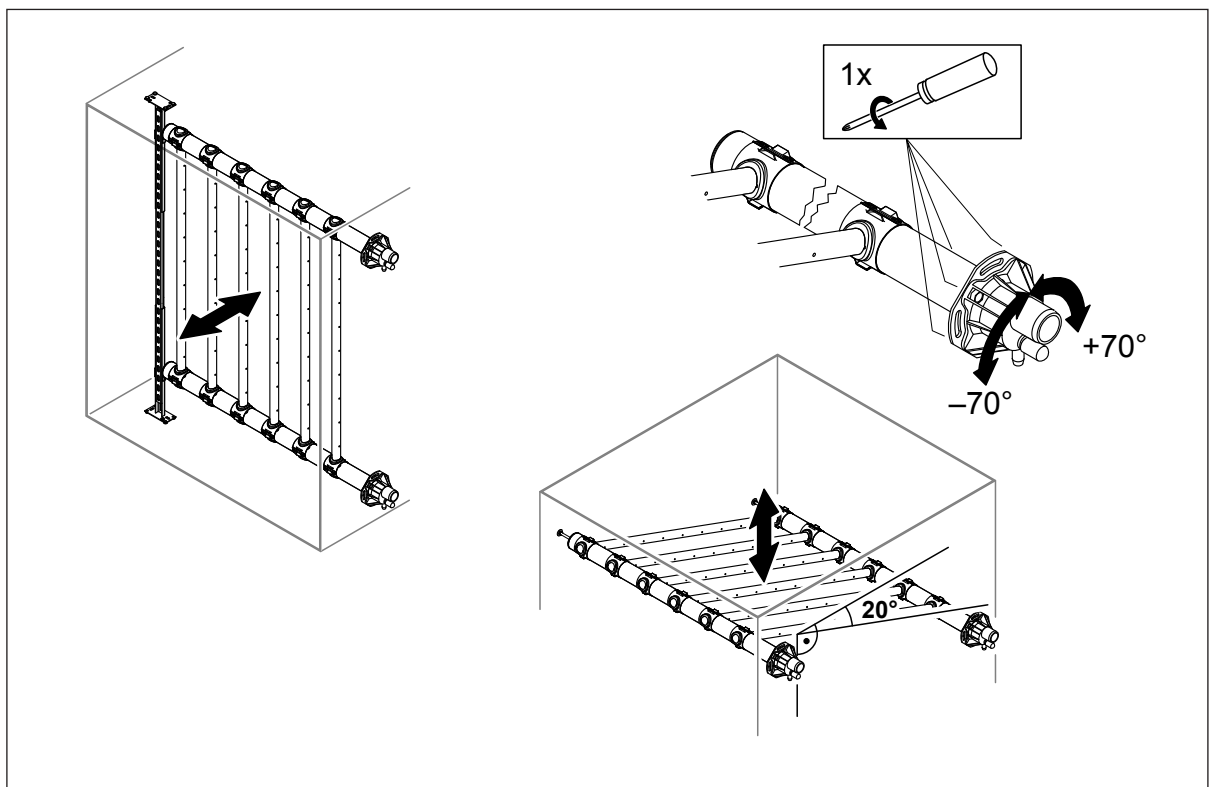

3.4 Mounting overview OptiSorp systems

System 1

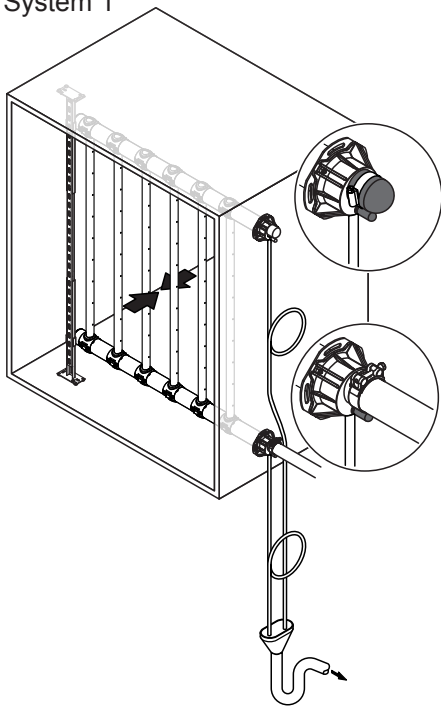

System 2

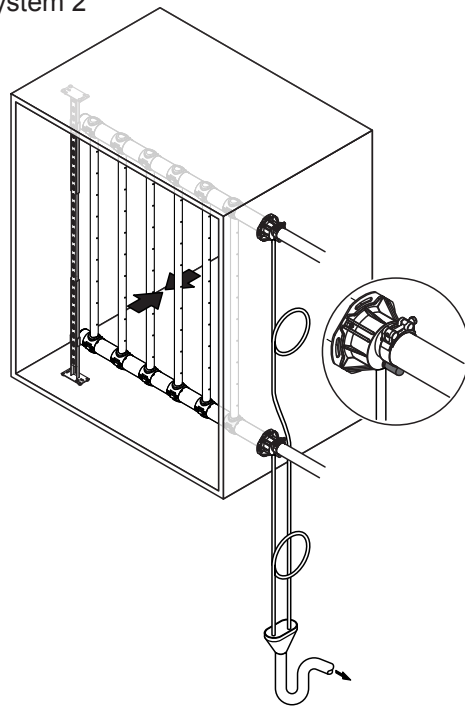

System 3

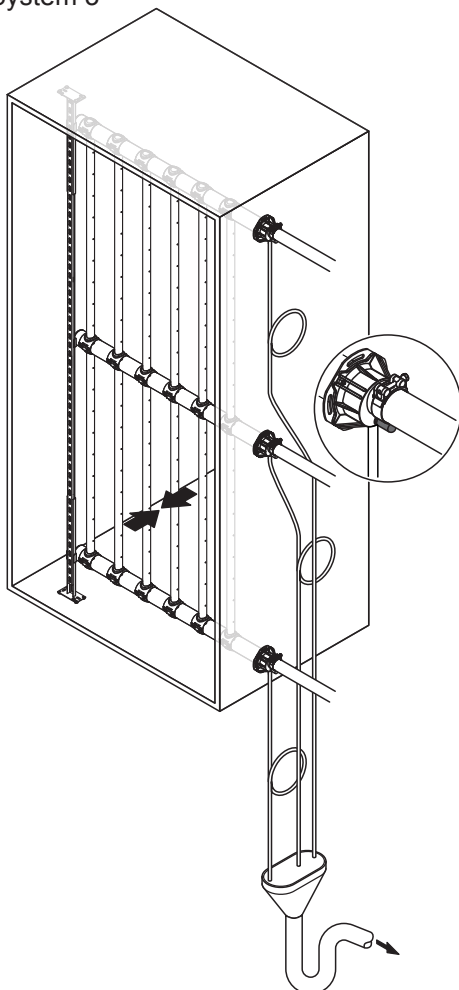

System 4

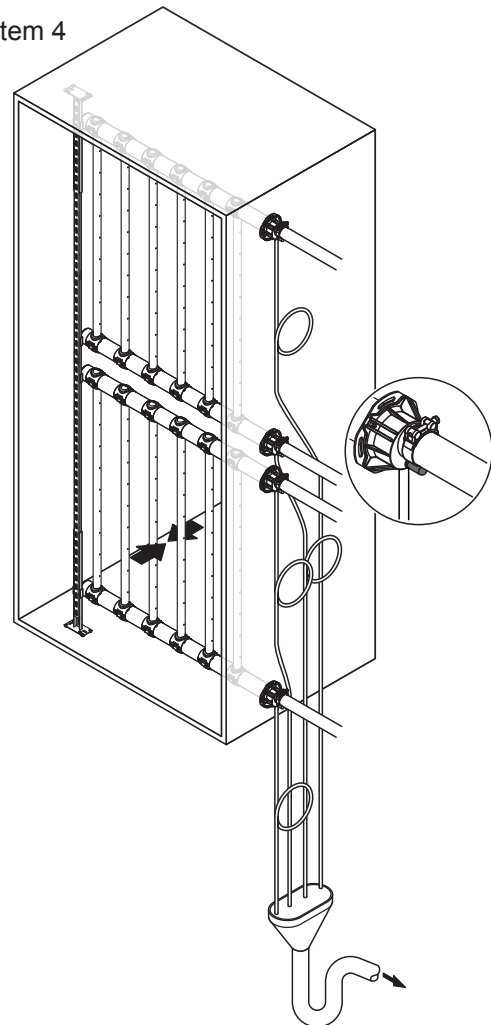

3.5 Mounting the premounted OptiSorp system

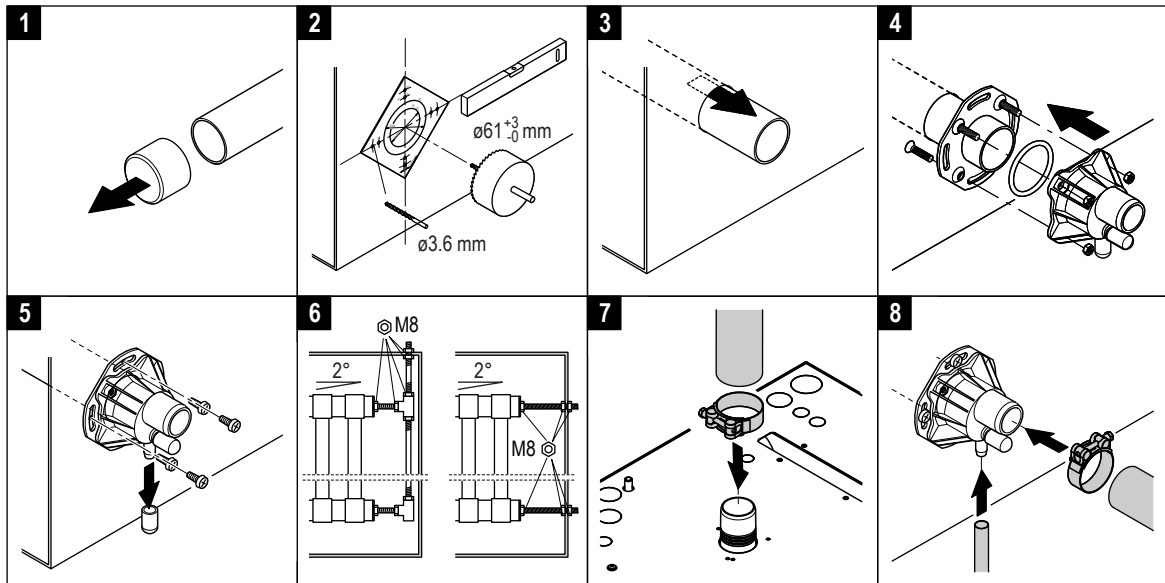

1. Remove the protection covers.
2. Measure the distance of the collector pipes and affix the installation template on the duct wall at the designed place with this distance (permissible variation ± 3 mm) and cut out the openings.
3. From inside of duct, insert the collector pipes through the prepared openings.
4. Slip from the outside flange, O-ring and steam hose connections onto the tube and fix them by the four screws. Pay attention that the condensate drains are below the steam hose connection.
5. Starting with the lowest collector pipe fix the steam hose connections with the 4 screws at the duct wall.
6. Align the collector pipes with a down-slope of 2° against the steam connector. Then, fasten the pipe ends on the duct using M8 threaded rod or the specially designed support available as accessory (see mounting drawing in [chapter 3.7](#)).
7. Connect the steam hose(s) to the steam outlet connector(s) of the humidifier and fasten with the hose clamp(s). Then lead the steam hose(s) to the collector pipe(s) according to the instructions for the hose layout in the installation manual of the corresponding humidifier.
Note: The Condair GS devices 65 ..., 90 ..., 130 ..., 195 ... and 260 ... are supplied with connection adapters for the steam hose installation. Please observe the special instructions in the installation manual for the Condair GS when installing these adapters.
8. Connect the steam hose(s) DS80 and the condensate hoses to the collector pipes according to the overview in [chapter 3.4](#). Secure the steam hose(s) to the collector pipe(s) with the hose clamp and guide the condensate hoses downwards into an open discharge funnel.
Note: For system 1, connect the steam hose to the lower steam connector and close the upper steam connector with the supplied sealing cap and the hose clamp.

3.6 Mounting the different parts of the OptiSorp system

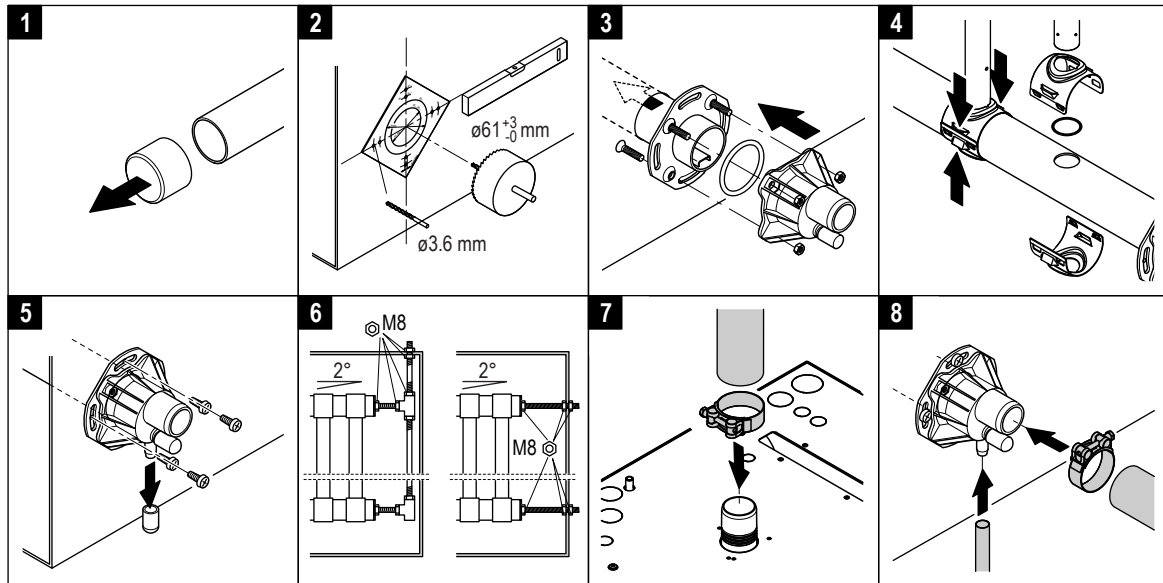

1. Remove the protection covers.
2. Affix the installation templates on the duct wall at the designed place with the correct distance of the collector pipes (permissible variation ± 3 mm). Cut out the openings.
3. Slip the flange, O-ring and steam hose connections onto the tube and fix them by the four screws. From outside of the duct, insert the premounted collector pipes through the prepared openings.
4. Put one half tube clip with O-ring onto both ends of the nozzle pipes. Slide the nozzle pipes into the holes of the collectors to the limit stop and so that the nozzles are situated one against the others. With a suitable clamp press both halves of the clips together until they will be fixed by a “click”.
5. Starting with the lowest collector pipe fix the steam hose connections with the 4 screws at the duct wall.
6. Align the collector pipes with a down-slope of 2° against the steam connector. Then, fasten the pipe ends on the duct using M8 threaded rod or the specially designed support available as accessory (see mounting drawing in [chapter 3.7](#)).
7. Connect the steam hose(s) to the steam outlet connector(s) of the humidifier and fasten with the hose clamp(s). Then lead the steam hose(s) to the collector pipe(s) according to the instructions for the hose layout in the installation manual of the corresponding humidifier.
 Note: The Condair GS devices 65 ..., 90 ..., 130 ..., 195 ... and 260 ... are supplied with connection adapters for the steam hose installation. Please observe the special instructions in the installation manual for the Condair GS when installing these adapters.
8. Connect the steam hose(s) DS80 and the condensate hoses to the collector pipes according to the overview in [chapter 3.4](#). Secure the steam hose(s) to the collector pipe(s) with the hose clamp and guide the condensate hoses downwards into an open discharge funnel.
 Note: For system 1, connect the steam hose to the lower steam connector and close the upper steam connector with the supplied sealing cap and the hose clamp.

3.7 OptiSorp Support (accessory)

Range duct height [mm]	Art./SAP No.	Upper foothold (Pos. 1) Length [mm]	Rail (Pos. 2) Length [mm]	Lower foothold (Pos. 3) Length [mm]	Bracket (Pos. 4)
450...950	1117477	450	500	none	4
950...1350	1117478	450	500	450 mm	4
1350...2300	1117479	450	1400	450 mm	4
2300...3200	1117480	450	2300	450 mm	4

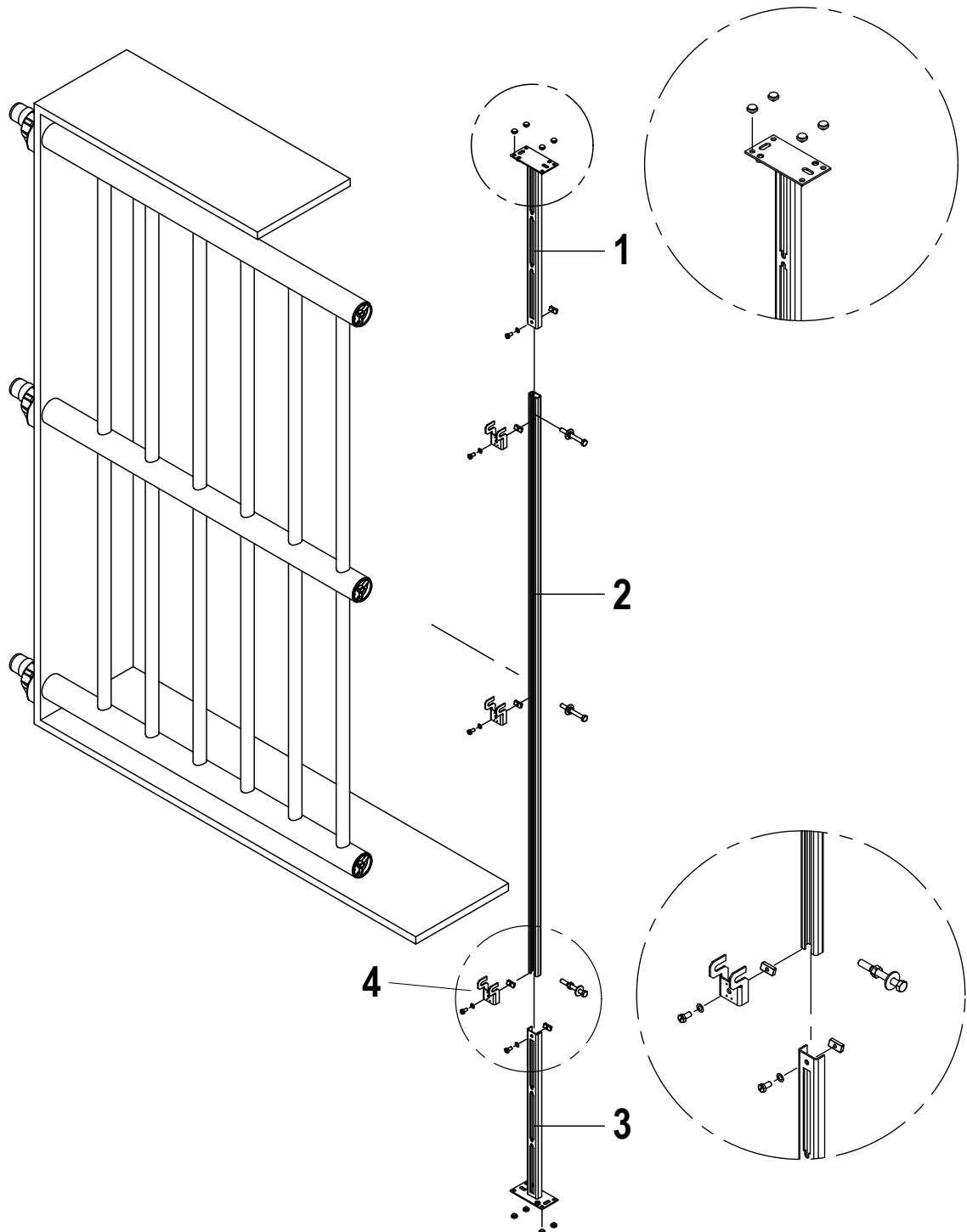

4 Putting into operation and operation

4.1 Putting into operation

When connected to several basic units these should be operated in parallel. Otherwise condensate runs into the units switched off and fills these until overflow occurs. Problems can then arise when switching on again.

The following should be ensured when putting into operation:

1. that the system pressure don't increase over 1500 Pa. The system pressure is componed of the airduct static pressure, the pressure drop over the OptiSorp system (typical 500 Pa) and the back pressure in the steam hose (typical 100 Pa/m)
2. that no water splashes from the steam distribution system and the condensate runs out of the system satisfactorily. Condensating formation may be caused by:
 - Steam supply pipe not properly drained
 - Metallic steam pipe inadequately insulated
 - Overstressed steam generator feeds water through steam pipe
 - System condensate drain is blocked
 - Extreme back-pressure in condensate hose
 - Incorrect installation of condensate hose

4.2 Operation

- Carry out visual checks periodically
- Further details according to the installation and operating instructions of the humidifier

5 Spare parts list

Pos.	Article	Type	Art./SAP-No.
1	Flange connection cpl. DV81	ø45	1113746
2	O-ring (3 pcs)	ø59.69 x ø5.34	1119190
3	Sealing cap with fixation		1117559
4	Sealing cap ø10 (3 pcs)		2559239
5	Hose clamp (2 pcs)	DV81 with DS80	2538896
		DV81 with Z10	2538898
6	Internal sealing	DV81	2526236
7	Hose clamp with O-ring		1117893
8	O-ring for hose clamp (5 pcs)		1118549
9	Sealing cap steam connector ø41 mm with hose clamp		2567039

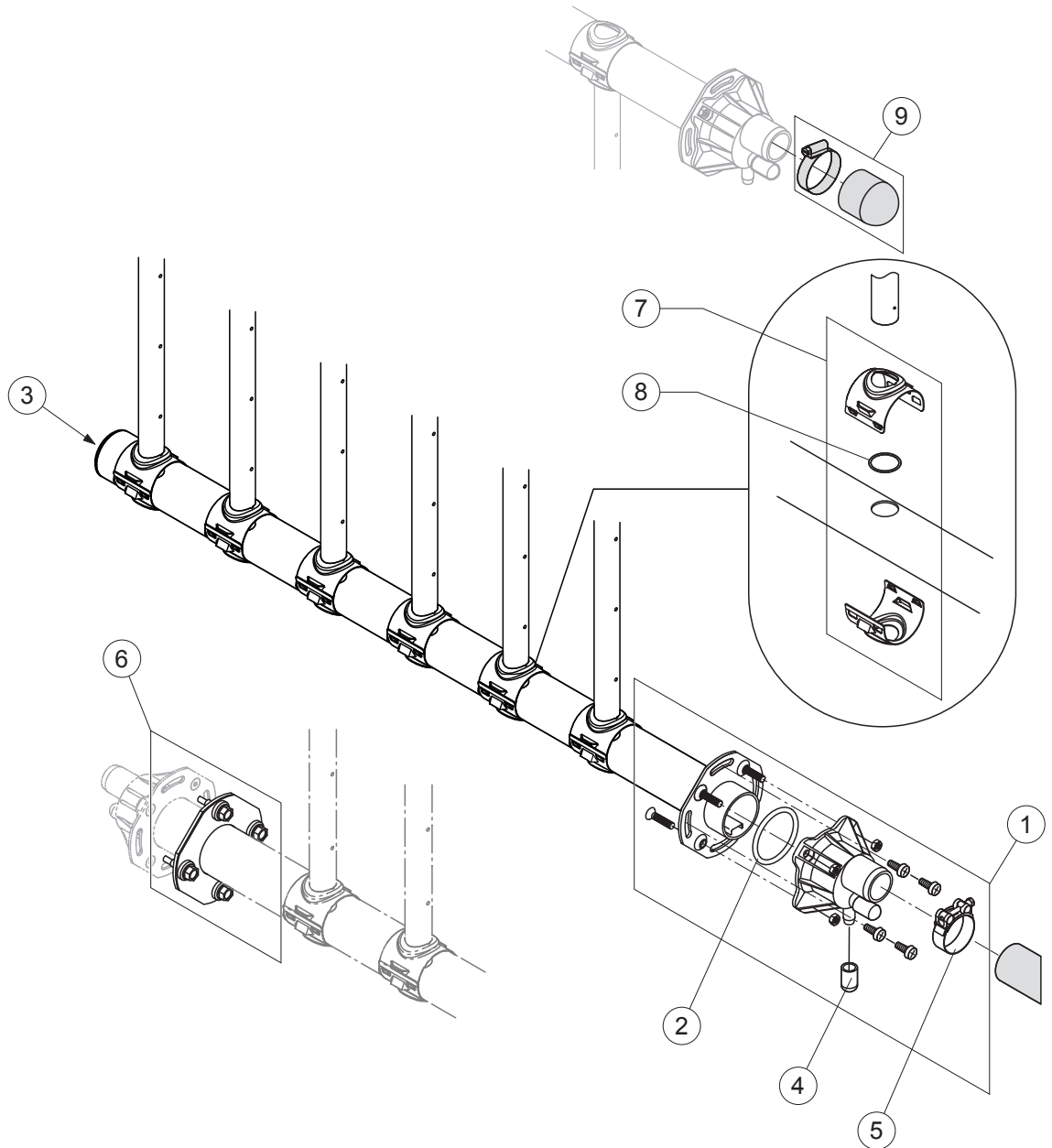

6 Appendix

6.1 Drilling template

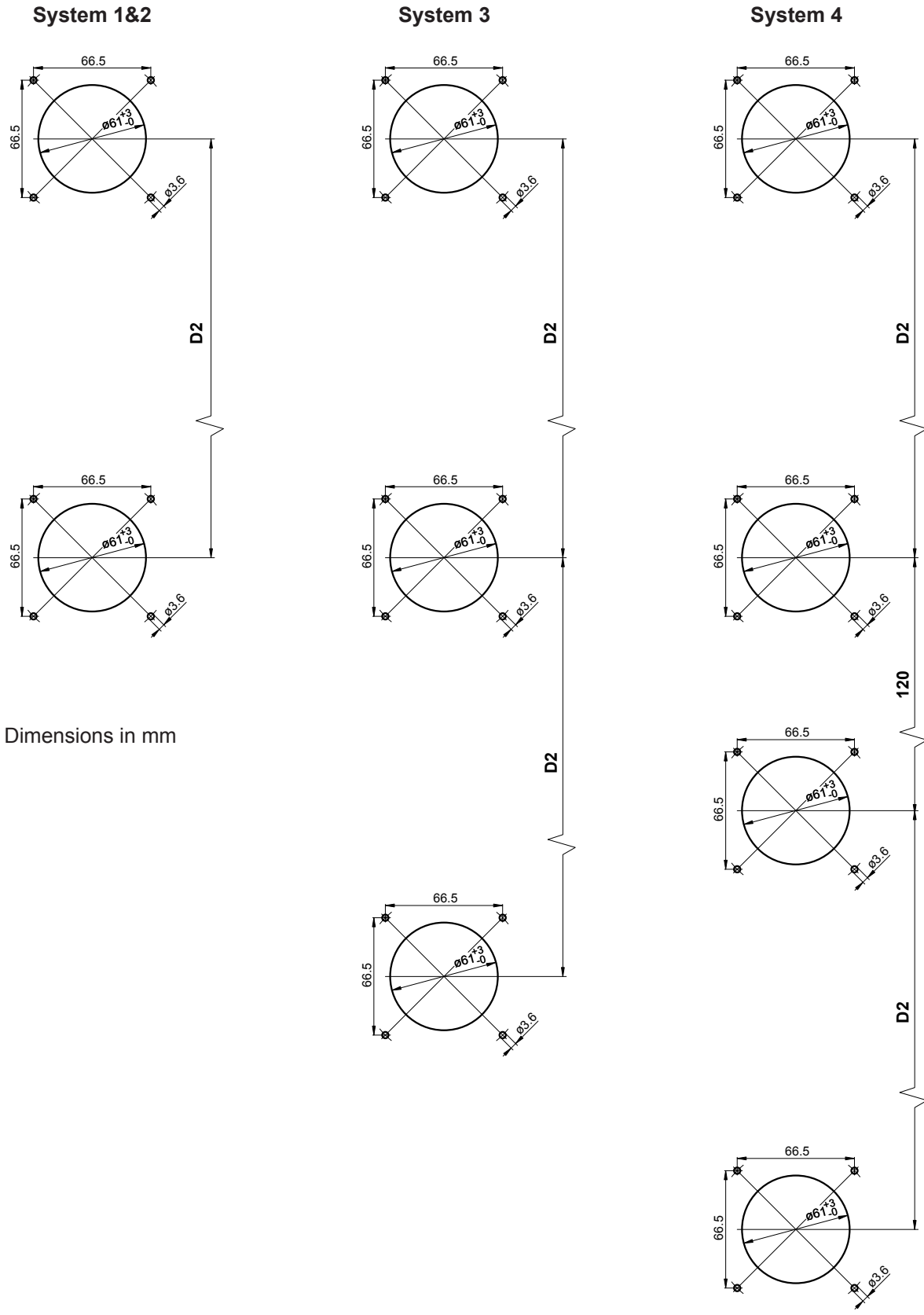

Notes

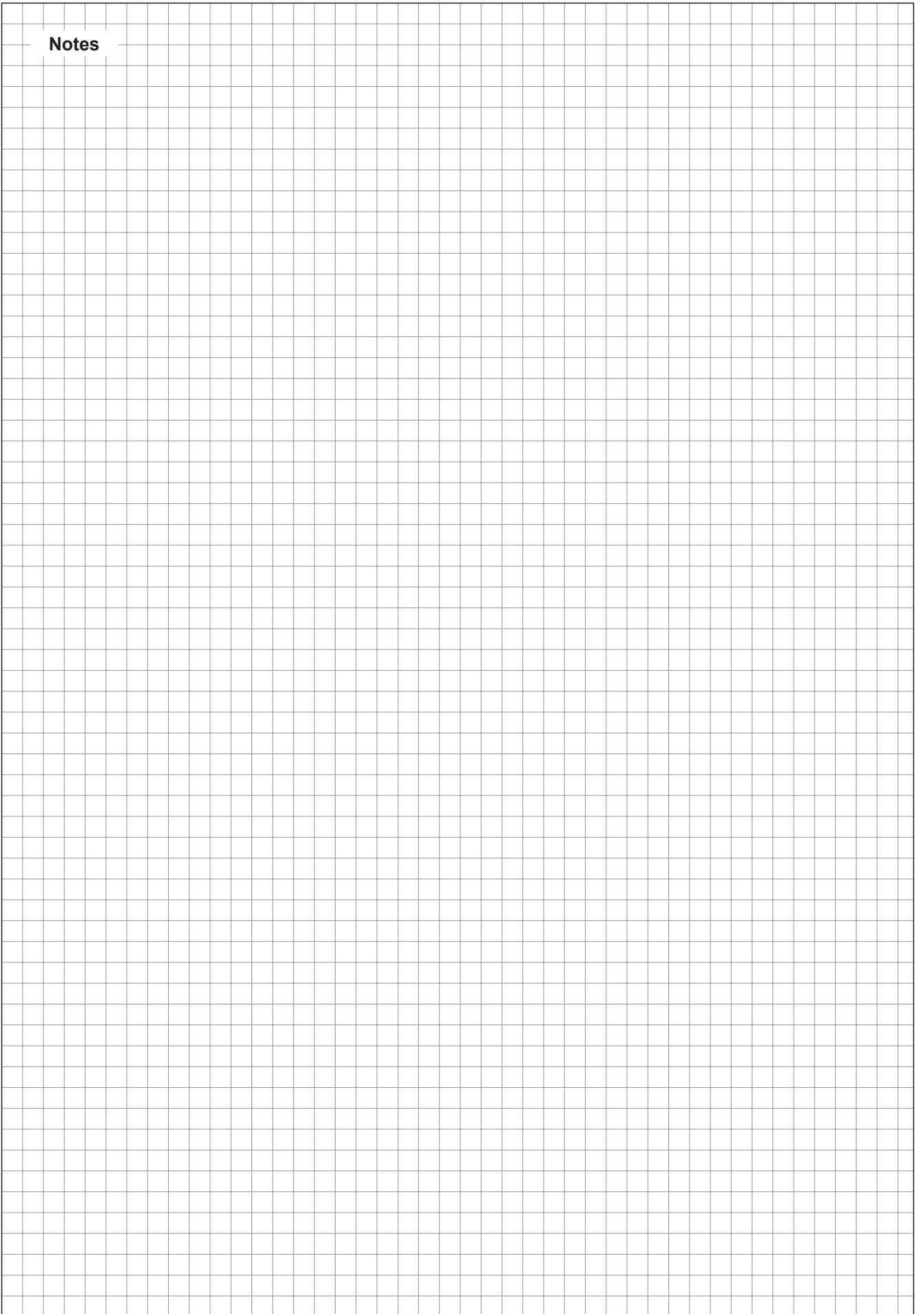

Notes

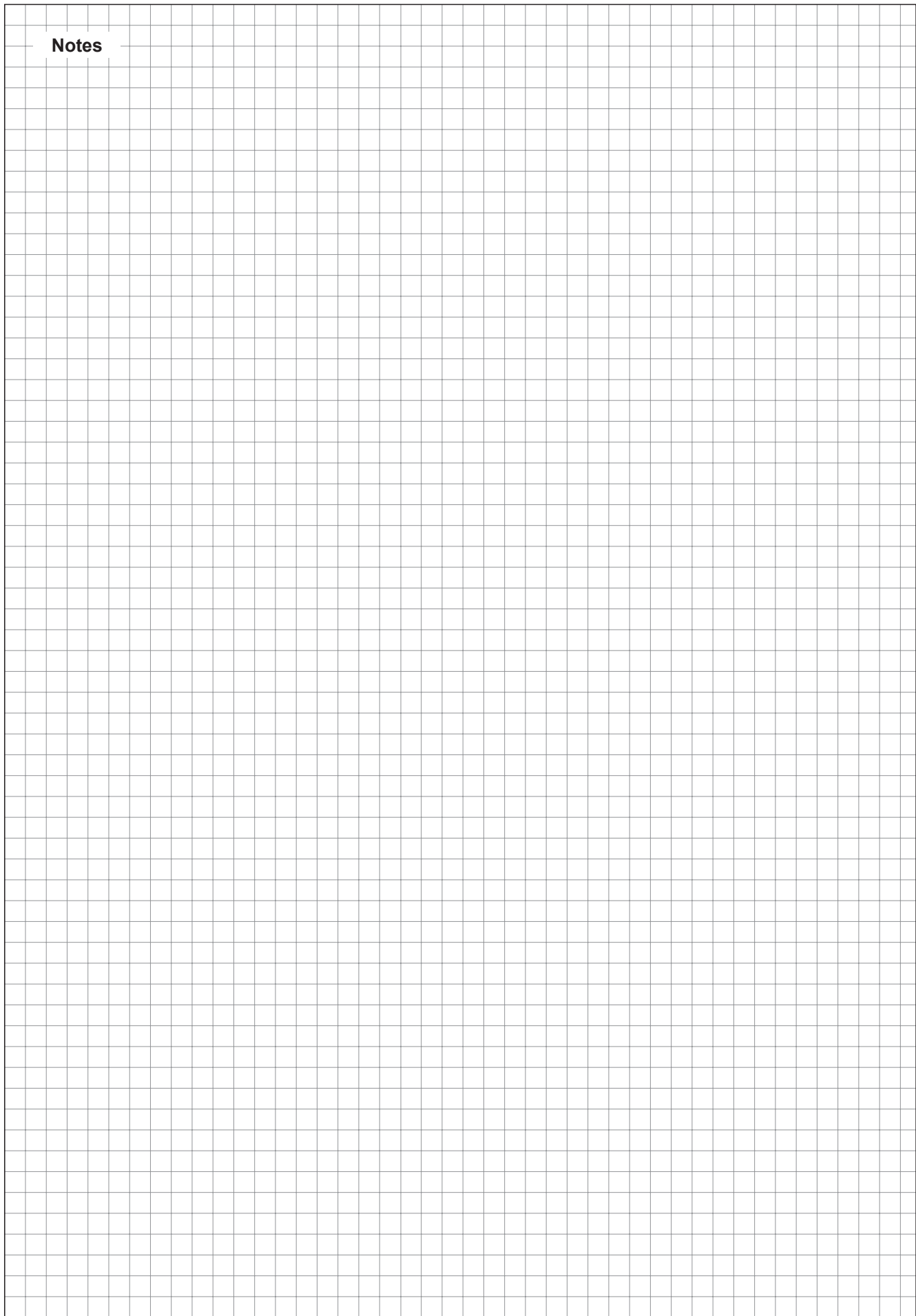

CONSULTING, SALES AND SERVICE:



CH94/0002.00

Condair Group AG
Gwattstrasse 17, 8808 Pfäffikon SZ, Switzerland
Phone +41 55 416 61 11, Fax +41 55 588 00 07
info@condair.com, www.condairgroup.com

